

iX T12B Installation Guide

1 Safety Precautions

Both the installer and the owner and/or operator of the operator panel must read and understand this installation manual.

1.1 General

- Read the safety precautions carefully.
- Check the delivery for transportation damage. If damage is found, notify the supplier as soon as possible.
- Do not use the operator panel in an environment with high explosive hazards.
- The supplier is not responsible for modified, altered or reconstructed equipment.
- Use only parts and accessories manufactured according to specifications of the supplier.
- Read the installation and operating instructions carefully before installing, using or repairing the operator panel.
- Never allow fluids, metal filings or wiring debris to enter any openings in the operator panel. This may cause fire or electrical shock.
- Only qualified personnel may operate the operator panel.
- Storing the operator panel where the temperature is lower/higher than recommended in this manual can cause the LCD display liquid to congeal/become isotopic.
- The LCD display liquid contains a powerful irritant. In case of skin contact, wash immediately with plenty of water. In case of eye contact, hold the eye open, flush with plenty of water and get medical attention.
- The figures in this manual serves an illustrative purpose. Because of the many variables associated with any particular installation, the supplier cannot assume responsibility for actual use based on the figures.
- The supplier neither guarantees that the operator panel is suitable for your particular application, nor assumes responsibility for your product design, installation or operation.
- It is recommended to turn on and shut down the operator panel at least once before installing any components/cards or before connecting the operator panel to external devices, like for example serial devices.

1.2 UL and cUL Installation

- This equipment is suitable for use in Class 2 non-hazardous locations only. [Combinations of equipment in your system are subject to investigation by the local authority having jurisdiction at the time of installation].
- All devices have to be supplied by a Class 2 power supply.



Warning:
Do not disconnect equipment unless power has been removed or the area is known to be non-hazardous

- For Canada also AVERTISSEMENT – AVANT DE DECONNECTER L'EQUIPEMENT, COUPER LE COURANT OUS'ASSURER QUE L'EMPLACEMENT EST DESIGNE NON DANGEREUX.



Warning:
Only UL and cUL approved expansion units are allowed to be connected to the port designated "EXPANSION". At the moment there are no such units evaluated or allowed.



Warning:
Do not replace expansion unit unless power has been switched off or the area is known to be non-hazardous.

- This product contains a battery; this must only be changed in an area known to be non-hazardous.
- Replace the battery with a BR 2032 battery. Use of another type of battery may present a risk of fire or explosion.



Warning:
Battery may explode if mistreated. Do not recharge, disassemble or dispose of in fire.

- For use on a flat surface of a type 4X enclosure indoor use only.
- Use 75 degree conductors only
- Use copper conductors only
- To make wiring connections to the power supply connector, follow the table with cable and torque specifications below:

Terminal Block No.	Wire Size AWG	TQLb.In.
X1/X100 Phoenix connectors	AWG 30-12	5-7
X1/X100 Anytek connectors	AWG 24-12	3.5

- These devices are Class 2 supplied programmable controllers (industrial PCs) for the use in industrial control equipment and are intended to be (front) panel mounted (Type 1 and 4x for indoor use only).

1.3 During Installation

- The operator panel is designed for stationary installation on a plane surface, where the following conditions are fulfilled:
 - no high explosive risks
 - no strong magnetic fields
 - no direct sunlight
 - no large, sudden temperature changes

- Install the product according to the accompanying installation instructions.
- Ground the product according to the accompanying installation instructions.
- Only qualified personnel may install the operator panel.
- Separate the high voltage, signal and supply cables.
- Make sure that the voltage and polarity of the power source is correct before connecting the product to the power outlet.
- Peripheral equipment must be appropriate for the application and location.

1.4 During Use

- Keep the operator panel clean.
- Emergency stop and other safety functions may not be controlled from the operator panel.
- Do not use too much force or sharp objects when touching the keys, touchscreen etc.

1.5 Service and Maintenance

- Only qualified personnel should carry out repairs.
- The agreed warranty applies.
- Before carrying out any cleaning or maintenance operations, disconnect the equipment from the electrical supply.
- Clean the display and surrounding front cover with a soft cloth and mild detergent.
- Replacing the battery incorrectly may result in explosion. Only use batteries recommended by the supplier. During the warranty period, the battery needs to be replaced by an authorized Beijer Electronics service center.

1.6 Dismantling and Scrapping

- The operator panel or parts thereof shall be recycled according to local regulations.
- The following components contain substances that might be hazardous to health and the environment: lithium battery, electrolytic capacitor and display.

1.7 Appearance of Air in Touch Screen

- The layer structure of the touch screen contains air and in rare cases appearance of bubbles can arise. This is purely cosmetic and does not affect any functionality of the panel. The appearance can occur under certain environmental conditions such as temperature, humidity, and atmospheric pressure.

2 Installation

2.1 Space Requirements

- Maximum installation plate thickness: 8 mm
- Space requirements in millimeters when installing the operator panel:

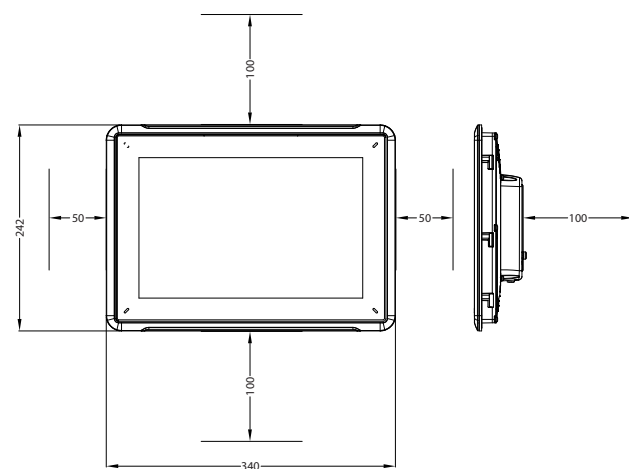

Note:
The dimensions on the drawing are not proportional.

2.2 Installation Process

The following is needed:

- A Torx TX7 screwdriver

1. Unpack and check the delivery. If damage is found, notify the supplier.

Note:

Place the operator panel on a stable surface during installation. Dropping the panel or letting it fall may cause damage.

2. Use the cut out dimensions that are included on the outline drawing, found in section *Operator Panel Drawings* and in the *Technical Data* table, to cut a correct opening in the cabinet. A separate cut out drawing is available for download from the Beijer Electronics web site.
3. Secure the operator panel in position by screwing the M4 Torx screw, allowing the built-in bracket to tighten against the panel:

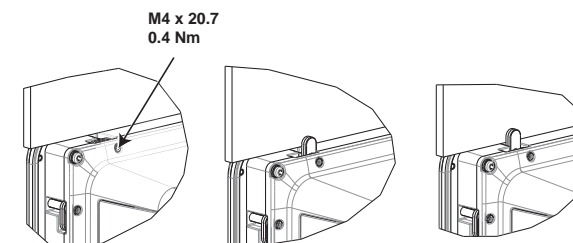

4. Connect the cables in the specified order, according to the drawing and steps below.

Caution:

- Ensure that the operator panel and the controller system have the same electrical grounding (reference voltage level), otherwise errors in communication may occur.
- The operator panel must be brought to ambient temperature before it is started up. If condensation forms, ensure that the operator panel is dry before connecting it to the power outlet.
- Ensure that the voltage and polarity of the power source is correct.
- Use only shielded communication cables.
- Separate high voltage cables from signal and supply cables.

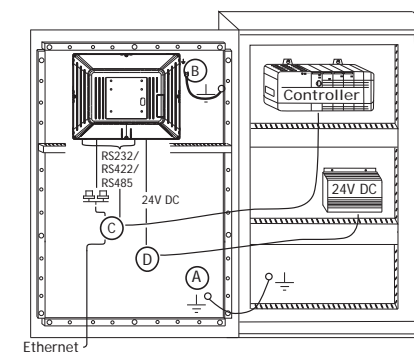

- Connect cable A.
- Connect cable B, using an M5 screw and a grounding conductor (as short as possible) with a cross-section of minimum 2.5 mm².
- Connect cable C.
- Connect cable D. The recommended cross-section of the cable is 1.5 mm².

5. Carefully remove the laminated film over the operator panel display, to avoid static electricity that could damage the panel.

2.2.1 Connections to the Controller

For information about the cables to be used when connecting the operator panel to the controller, please refer to the help file for the driver in question.

2.2.2 Other Connections and Peripherals

Cables, peripheral equipment and accessories must be suitable for the application and its environment. For further details or recommendations, please refer to the supplier.

3 Technical Data

Parameter	iX T12B
Front panel, W × H × D	340 × 242 × 79 mm
Cut out dimensions, W × H	324 × 226 mm
Mounting depth	72 mm (172 mm including clearance)
Standalone mounting	VESA 75 × 75 Note: Maximum screw length for VESA mounting is 4 mm. Usage of longer screws may lead to damage.
Front panel seal	IP 65
Rear panel seal	IP 20
Touch screen material	Polyester on glass, resistive. Overlay: Autoflex EBA 180L ⁽¹⁾ .
Touch screen operations	1 million finger touch operations
Reverse side material	Powder-coated aluminum
Frame material	Powder-coated aluminum
Weight	2.6 kg
Serial port for COM1 RS232 and COM2 RS422/RS485	9-pin D-sub contact with RS232 RTS/CTS, chassis-mounted female with standard locking screws 4-40 UNC
Serial port for COM3 RS232 and COM4 RS422/RS485	9-pin D-sub contact with RS232 RTS/CTS, chassis-mounted female with standard locking screws 4-40 UNC
Ethernet	1 × 10/100/1000 Mbit/s and 1 × 10/100 Mbit/s. Shielded RJ45
USB	3 × USB Host 2.0, max output current 500 mA
Processor	Intel® Atom
External storage media	1 × SD card (optional). Only compatible with the standard SD format with up to 2 GB storage capacity.
Memory RAM	1 GB
LED	1 × multi-color
Real time clock	Yes (on chip)
Battery	Lithium battery type BR 2032 (or CR 2032), exchangeable
Power consumption at rated voltage	22 W
Fuse	3.15 A Slow
Power supply	+24 V DC (18-32 V DC) CE: The power supply must conform with the requirements according to IEC 60950 and IEC 61558-2-4. UL and cUL: The power supply must conform with the requirements for class II power supplies.
Display	TFT-LCD with LED backlight. 1280 × 800 pixels, 262 k colors
Active area of display, W × H	261.12 × 163.2 mm
Operating temperature	-10 °C - +50 °C
Storage temperature	-20 °C - +70 °C
Relative humidity	5% - 85% non-condensed
Approvals and certifications	Information is available on the web site www.beijerelectronics.com

⁽¹⁾ See section *Chemical Resistance* for more information.

4 Chemical Resistance

4.1 Metal Casing

The frame and casing material is powder-coated aluminum. This powder paint withstands exposure to the following chemicals without visible change:

Acetic acid 10%	Phosphoric acid 4%
Citric acid 10%	Phosphoric acid 10%
Diesel	Sea water
Distilled water	Sodium chloride 2%
Edible oil	Sodium chloride 20%
Fuel oil	Sulphuric acid 20%
Hydrogen peroxide 3%	Tap water

The powder paint shows limited resistance to the following chemicals at room temperature:

Butanol	Nitric acid 3%
Hydrochloric acid 5%	Nitric acid 10%
Isopropyl alcohol	Phosphoric acid 43%
Na-hypochlorite 10%	Turpentine

Note:

If exposure to any of the above chemicals is demanded, it is recommended to first test the chemical in a hidden spot of the metal casing.

The powder paint shows little or no resistance to the following chemicals at room temperature:

Acetic acid, conc.	Methyl-ethyl ketone	Toluene
Acetone	Nitric acid 30%	Trichlorethylene
Ammonia 5%	Phenol	Xylene
Ammonia, conc.	Sodium hydroxide 5%	97 octane unleaded petrol
Ethyl acetate	Sodium hydroxide 30%	98 octane leaded petrol

4.2 Touch Screen and Overlay

4.2.1 Autoflex EBA 180L

Autoflex EBA 180L covers the overlay surrounding the touch screen.

Solvent Resistance

Autoflex EBA 180L withstands exposure of more than 24 hours duration under DIN 42 115 Part 2 to the following chemicals without visible change:

Acetonitrile	Diesel Downey / Lenor ⁽¹⁾	Phosphoric acid (<30%)
Ajax / Vim in solution	Ethanol	Potassium ferricyanide
Alkalicarbonate solution ⁽¹⁾	Glycerine	Potassium hydroxide (<30%)
Ammonia (<40%) ⁽¹⁾	Glycol	Pure Turpentine
Acetic acid (<50%)	Gumption ⁽¹⁾	SBP 60/95 ⁽¹⁾
Ariel powder in solution ⁽¹⁾	Hydrochloric acid (<36%)	Sulfuric acid (<10%)
Bleach ⁽¹⁾	Linseed oil	Tomato ketchup
Castor oil	Methanol	Trichloroacetic acid (<50%)
Caustic soda (<40%) ⁽¹⁾	Nitric acid (<10%)	White Spirit
Cutting oil	Paraffin oil	Windex ⁽¹⁾
Cyclohexanol	Persil powder in solution ⁽¹⁾	Wisk
Diacetone alcohol	Petroleum spirit ⁽¹⁾	-

⁽¹⁾ Extremely faint glossing of the texture was noted.

Autoflex EBA 180L withstands DIN 42 115 Part 2 exposure of up to 1 hour duration to glacial acetic acid without visible change.

Autoflex EBA 180L is not resistant to high pressure steam at over 100 °C or the following chemicals:

Concentrated mineral acids	Benzyl alcohol
Concentrated caustic solution	Methylene chloride

4.2.2 Touch Screen Surface

The touch screen surface on the operator panel withstands exposure to the following solvents without visible change:

Solvents	Time
Acetone	10 minutes
Isopropanol	10 minutes
Toluene	5 hours

4.2.3 Autoflex EBA 180L

It is recommended to use the Autoflex EBA 180L touch display protection film, that can be ordered from Beijer Electronics.

Solvent Resistance

Autoflex EBA 180L withstands exposure to the same chemicals as Autotex F157 or F207 according to section [Autoflex EBA 180L](#).

Outdoor Use

In common with all polyester based films, Autoflex EBA 180L is not suitable for use in conditions of long-term exposure to direct sunlight.

5 Operator Panel Drawings

5.1 Connectors

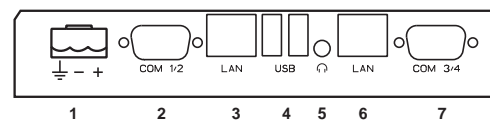

Pos.	Connector	Description
1	Power supply	+24 V DC (18-32 V DC)
2	COM 1/2	Communication Ports
3	LAN (Port 2)	1 × 10/100 Base-T (shielded RJ-45)
4	USB	2 × USB Host 2.0, max output current 500 mA
5	Headphone	Headphone Connector
6	LAN (Port 1)	1 × 10/100/1000 Base-T (shielded RJ-45)
7	COM 3/4	Communication Ports

5.2 Communication Ports

Pin	Serial port, 9-pin female		Serial port, 9-pin female	
	COM1	COM2	COM3	COM4
1	-	RS422 Tx+ RS485 Tx+/Rx+	-	RS422 Tx+ RS485 Tx+/Rx+
2	RS232 RxD	-	RS232 RxD	-
3	RS232 TxD	-	RS232 TxD	-
4	-	RS422 Rx+	-	RS422 Rx+
5	GND	GND	GND	GND
6	-	RS422 Tx- RS485 Tx-/Rx-	-	RS422 Tx- RS485 Tx-/Rx-
7	RS232 RTS	-	-	RS422 RTS+
8	RS232 CTS	-	-	RS422 RTS-
9	-	RS422 Rx-	-	RS422 Rx-

Note:

In order to utilize two communication ports on the same physical port, the Y-split cable CAB109 must be used. Drawing for external cable CAB109 (drawing # Z7100-029E) is available on the web site: www.beijerelectronics.com

5.3 iX T12B Outline

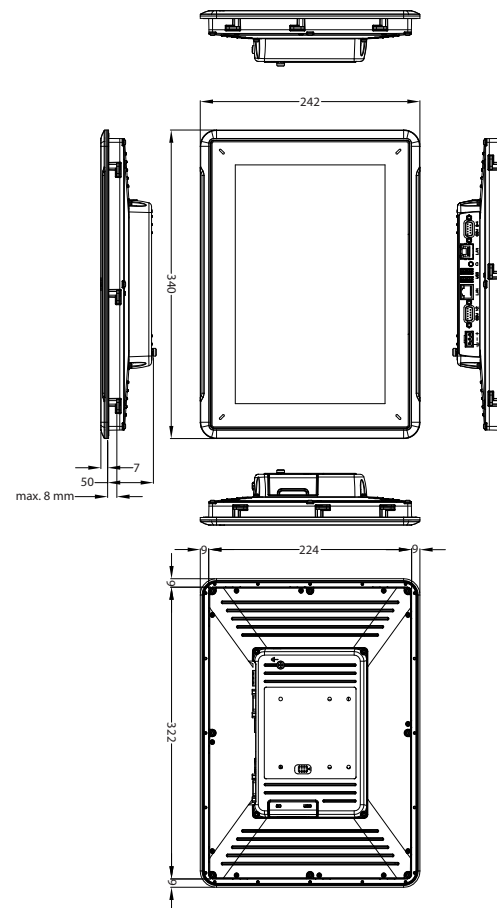

Note:

A Step CAD file is available on the web site www.beijerelectronics.com

Order no: MAEN096C

Copyright © 2013-09 Beijer Electronics. All rights reserved.

The information in this document is subject to change without notice and is provided as available at the time of printing. Beijer Electronics AB, including all its group companies, reserves the right to change any information without updating this publication. Beijer Electronics AB, including all its group companies, assumes no responsibility for any errors that may appear in this document. Read the entire installation manual prior to installing and using this equipment. Only qualified personnel may install, operate or repair this equipment. Beijer Electronics AB, including all its group companies, are not responsible for modified, altered or renovated equipment. Because the equipment has a wide range of applications, users must acquire the appropriate knowledge to use the equipment properly in their specific applications. Persons responsible for the application and the equipment must themselves ensure that each application is in compliance with all relevant requirements, standards and legislation in respect to configuration and safety. Only parts and accessories manufactured according to specifications set by Beijer Electronics AB, including all its group companies, may be used. BEIJER ELECTRONICS AB, INCLUDING ALL ITS GROUP COMPANIES, SHALL NOT BE LIABLE TO ANYONE FOR ANY DIRECT, INDIRECT, SPECIAL, INCIDENTAL OR CONSEQUENTIAL DAMAGES RESULTING FROM THE INSTALLATION, USE OR REPAIR OF THIS EQUIPMENT, WHETHER ARISING IN TORT, CONTRACT, OR OTHERWISE. BUYER'S SOLE REMEDY SHALL BE THE REPAIR, REPLACEMENT, OR REFUND OF PURCHASE PRICE, AND THE CHOICE OF THE APPLICABLE REMEDY SHALL BE AT THE SOLE DISCRETION OF BEIJER ELECTRONICS AB, INCLUDING ALL ITS GROUP COMPANIES.

Beijer
ELECTRONICS

Head office

Beijer Electronics AB

Box 426

201 24 Malmö, Sweden

www.beijerelectronics.com / +46 40 358600